

# **AMERITRON ATR-15 ANTENNA TUNER INSTRUCTION MANUAL**

The ATR-15 is a 1500 Watt R.F. output rated antenna tuner covering 1.8 through 30 MHz in 10 bands. Sufficient overlap is included to allow continuous coverage over the entire 1.8 to 30 MHz spectrum for commercial applications. The circuit is a standard "T" network.

The ATR-15 has a combination dual range peak reading wattmeter and SWR meter. The internal balun transformer can be connected for a 1:1 or a 4:1 ratio. The 7 amp switch and the 4.5 KV rated variable capacitors allow powers of up to 1500 watts to be handled on all bands except 1.8 MHz. Output rating on 1.8 MHz is 1000 watts.



# Theory Of Operation

The "Q" of a C-L-C "T" network increases as the value of "L" increases. This means that for maximum power handling capabilities a minimum value of inductance and "Q" (highest frequency setting on the band switch) should be selected. Some impedances may fall outside the range of the network and a higher "Q" will be required to extend the network range. This is

accomplished by switching the band selector to **the next** highest inductance value (lower frequency setting).

The ATR-15 will safely handle 1500 watts of power at 50 ohm nominal impedance throughout its operating range normal amateur service on all bands except 1.8 MHz. Output rating on 1.8 MHz is 1000 watts.

## Installation

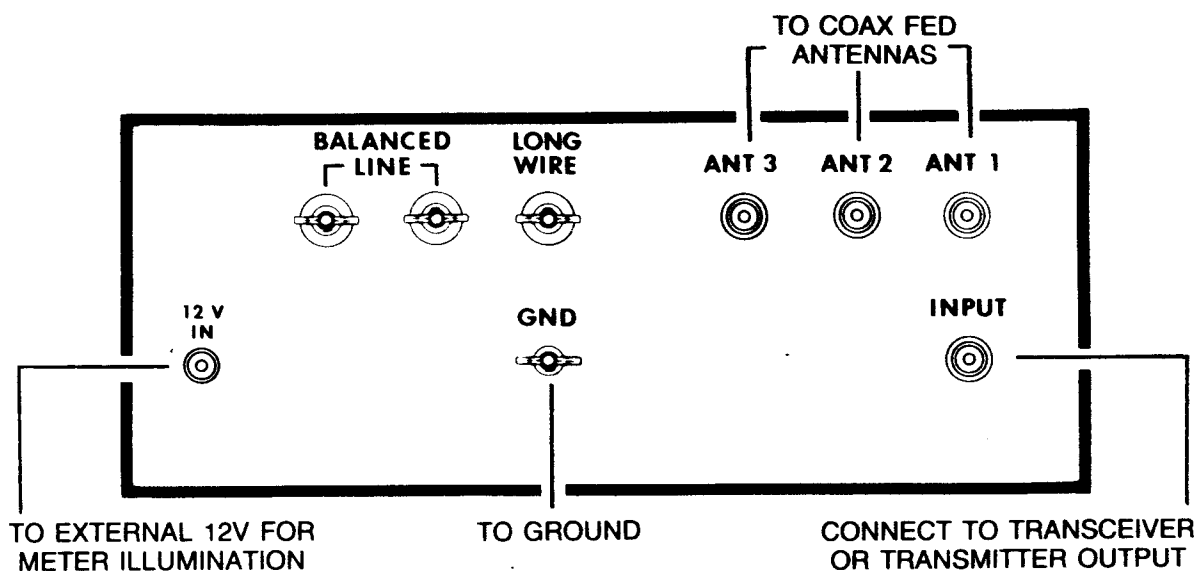

Locate the tuner at a convenient operating position. Use 50 ohm cable of known good quality between the tuner and the transceiver or transmitter.

Connect the transmitter or transceiver to the INPUT socket on the back panel with any convenient length of 50 ohm coaxial cable. Connect the antenna system to either the ANT 1, 2 or 3 sockets, the LONG WIRE terminal or the BALANCED LINE terminals as required.

Connect the GND post on the back panel to a good earth ground or to the station ground buss. Make this connection as short as possible and use a heavy gauge

solid wire. Grounding is very important with a types of antenna systems. The ARRL Antenn Handbook is an excellent source of information on antenna systems and how they function.

If meter illumination is desired, connect an external source of 12 volts to the 12 V IN socket.

If a linear amplifier, external wattmeter or a filter is use connect them between the ATR-1 5 and the transmitter ( transceiver. The ATR-1 5 is the last item to be connecte to the antenna system.

## Transmitter Adjustment

Broad band transmitters require no advance preparation. Transmitters with networks that require tuning should be adjusted on a dummy load prior to use with

the ATR-1 5. The control settings can be noted for future reference.

# Operation

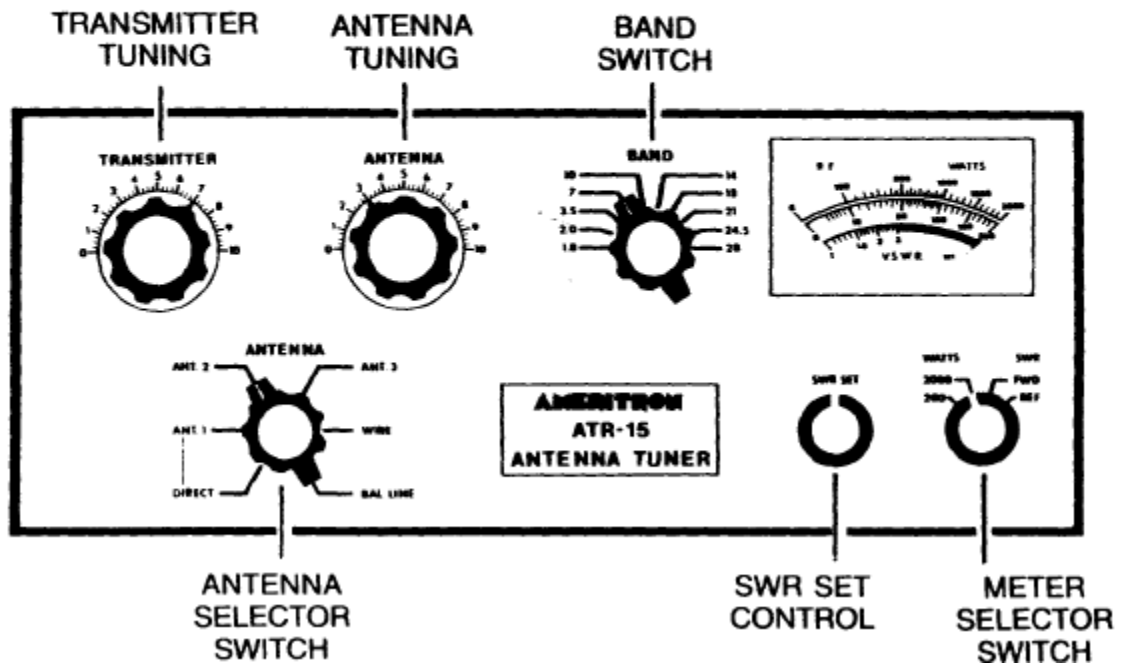

1. Pre-set the ATR-15 controls to the settings shown in the tuning chart for the desired band
2. Set the SWR SET control to the full clockwise position, place the meter selector switch in the FWD position.
3. Adjust the output level of the transmitter until full scale deflection occurs on the SWR meter. A power level of less than 10 watts will supply a full scale reading.
4. Place the meter selector switch in the REF position and adjust the TRANSMITTER and ANTENNA controls until the lowest SWR reading is obtained.
5. Gradually increase the transmitter power and readjust the TRANSMITTER and ANTENNA controls for

the lowest SWR reading until full output is reached. In the event that the antenna impedance is extremely high or low the next lowest setting of the band selector (counter-clockwise) may bring the network into resonance. Remember these extreme loading conditions may lower the power handling abilities of the ATR-15. If any arcing is heard immediately reduce the power level of the transmitter.

When the ATR-15 is used for receiving simply adjust TRANSMITTER and ANTENNA controls for maximum received signal with the band selector set to the closest receiving frequency.

## TUNING CHART

BAND	TRANSMITTER	ANTENNA
28	8	8
24.5	8½	8½
21	9	9
18	9	9
14	8	8
10	7½	7½

BAND	TRANSMITTER	ANTENNA
7	5¾	6
4.0	5½	6
3.5	3½	4¼
2.0	4	5
1.8	2¼	3½

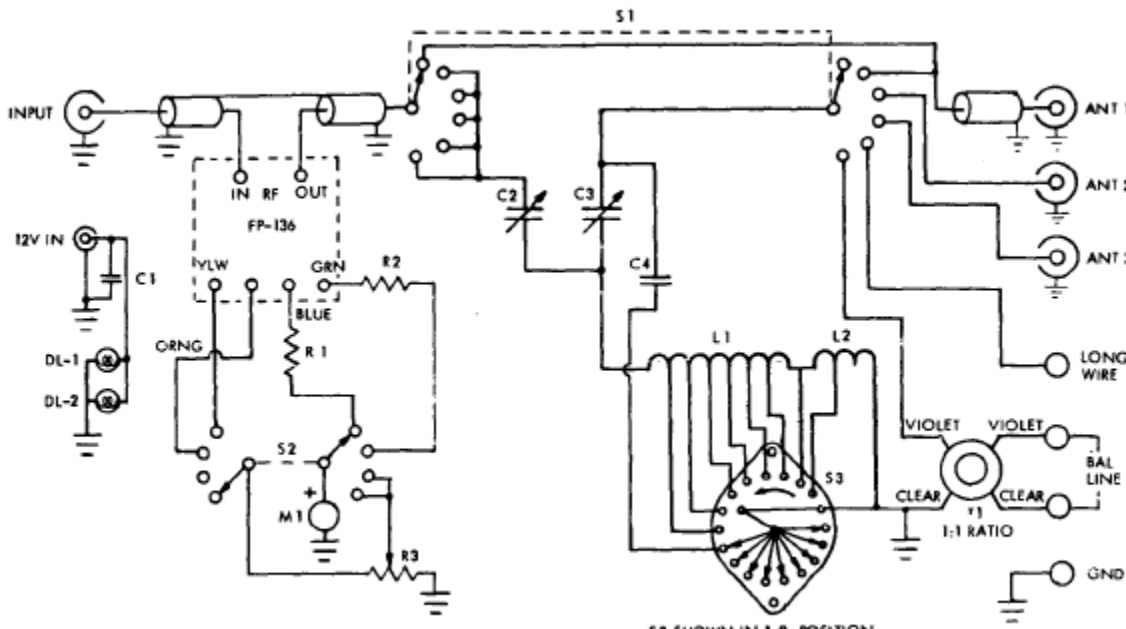

- C 1 .01uf, 50V disc (AR-553)
- C 2, C 3 225 uuf, 4.5KV (AR-553)
- C 4 170pf, 5KV (AR-559)
- DL-1, DL-2 12V lamp (AR-164)
- L 1 H F coil (FP-145)
- L 2 L F coil (AR-549)
- M 1 50ua meter (AR-59)
- R 1 120K ohm, 1/2W (AR-553)
- R 2 470K ohm, 1/2W (AR-552)
- S 1 Antenna switch (AR-547)
- S 2 Meter switch (AR-130)
- S 3 Band switch (AR-546)
- T 1 Balun (FP-137)

S3 SHOWN IN 1:1 POSITION, REAR VIEW. ARROW INDICATES DIRECTION OF ROTATION. SHOWN IN FULL CCW POSITION.

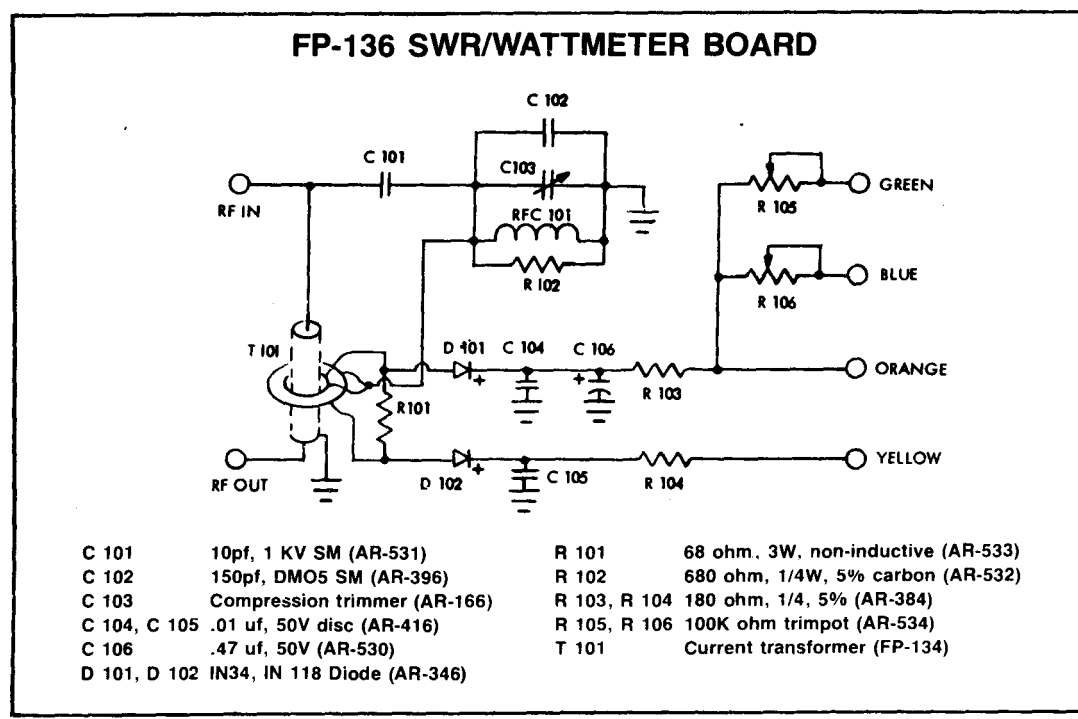
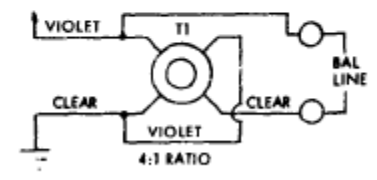

## ATR-15 BALUN

The balun in the ATR-15 functions as a choke-type current balancing device in the 1:1 ratio mode. The choke type balun is superior to conventional voltage balancing baluns because it supplies equal *currents* with 180° phase difference to minimize feedline radiation in any antenna system. Balanced *voltages* will not prevent feedline radiation.

In the 4:1 ratio mode the ATR-15 balun is a voltage balun. We recommend the 4:1 hookup only for conditions where the network in the ATR-15 will not be in range. To wire the balun with a 4:1 ratio, remove the violet wire connected to the balanced output terminal and attach it to the ground connection on the terminal strip (same point as the clear wire). Connect the 2 1/2" violet wire between the balanced output terminal and the violet wire at the top of the terminal strip (see illustration).

